

# B300RTH Rotating Beacon [Halogen Bulb]

**SPECTRA range:** The B300 series comprises Xenon strobe beacons, permanent filament bulb or halogen beacon, blinking filament bulb or halogen beacon, rotating beacon and a multi-function LED array beacon. The surface mount base can also be supplied with a right angle bracket or with a tube mounted assembly.

## Specifications:

Dimensions:	ø100 x 150mm
Termination:	1.5 mm <sup>2</sup> flying lead assembly
Cable entries:	1 x 5-7mm push through grommet 1 x M20 cable entry
Mounting:	Surface mount (bracket & pole mount accessories)
Lens colours:	Red, Amber, Blue, Clear, Green, Yellow
Lens types:	Prismatic or Plain
Construction:	Bayonet with anti-tamper locking screw
Housing/Lens:	PC (UL94V0 f1)
IP rating:	IP65
Temp. range:	-25°C to +50°C
RH:	90% at 20°C
Weight:	370g



**Part reference:** B300RTH

**B300**

**Light source:** Halogen Bulb G6,35 / GY6,35  
Rotating Beacon

**Rotation:** 180PM (+/-30RPM)

**Drive life:** >5,000 hrs

**Duty cycle:** 100%

**Light output:** 20W/25W

**Voltage:**

12V dc:	1.72A
24V dc:	0.91A
115V ac 50/60Hz:	216mA
230V ac 50/60Hz:	117mA

Part codes:	Voltage:
B300RTH012B/x	12V dc
B300RTH024B/x	24V dc
B300RTH115B/x	115V ac 50/60Hz
B300RTH230B/x	230V ac 50/60Hz

x = Lens colour:  
R=Red A=Amber B=Blue C=Clear G=Green  
Y=Yellow

## Mounting accessories:

Right angle bracket for wall mounting: B300RAB001  
Tube mounting assembly (140mm): B300TMA001

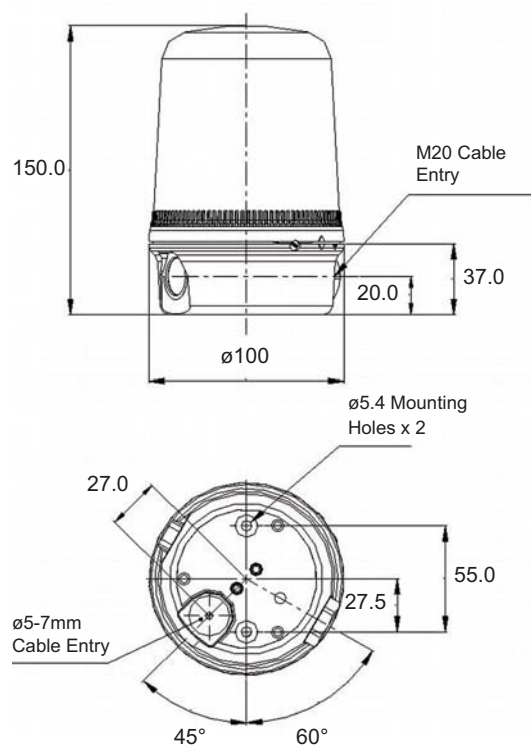

All dimensions in mm.



# B400RTH Rotating Beacon [Halogen Bulb]

**SPECTRA range:** The B400 series comprises Xenon strobe beacons, permanent filament bulb or halogen beacon, blinking filament bulb or halogen beacon, rotating beacon and a multi-function LED array beacon. The surface mount base can also be supplied with a right angle bracket or with a tube mounted assembly.

## Specifications:

Dimensions:	ø140 x 225mm
Termination:	1.5 mm <sup>2</sup> flying lead assembly
Cable entries:	1 x 5-7mm push through grommet 2 x M20 cable entry
Mounting:	Surface mount (bracket & pole mount accessories)
Lens colours:	Red, Amber, Blue, Clear, Green, Yellow
Lens types:	Prismatic or Plain
Construction:	Bayonet with anti-tamper locking screw
Housing/Lens:	PC (UL94V0 f1)
IP rating:	IP65
Temp. range:	-25°C to +50°C
RH:	90% at 20°C
Weight:	578g



**Part reference:** B400RTH

**Light source:** Halogen Bulb G6,35 / GY6,35  
Rotating Beacon

**Rotation:** 180PM (+/-30RPM)

**Drive life:** >5,000 hrs

**Duty cycle:** 100%

**Light output:** 35W/40W

**Voltage:**

12V dc:	3.0A
24V dc:	1.54A
115V ac 50/60Hz:	338mA
230V ac 50/60Hz:	186mA

Part codes:	Voltage:
B400RTH012B/x	12V dc
B400RTH024B/x	24V dc
B400RTH115B/x	115V ac 50/60Hz
B400RTH230B/x	230V ac 50/60Hz

x = Lens colour:  
R=Red A=Amber B=Blue C=Clear G=Green Y=Yellow

## Mounting accessories:

Right angle bracket for wall mounting: B400RAB001  
Tube mounting assembly (145mm): B400TMA001

