

B200STR Xenon Beacon Strobe

SPECTRA range: The B200 series comprises a xenon strobe beacon, permanent filament bulb beacon, blinking filament bulb beacon and a permanent LED array beacon. The surface mount base is supplied with neoprene mounting gasket and can also be supplied with a right angle bracket or with a tube mounting assembly.

Specifications:

Dimensions:	ø60 x 80mm
Terminals:	2.5 mm ²
Mounting:	Surface mount (bracket & pole mount accessories)
Lens colours:	Red, Amber, Blue, Clear, Green, Yellow
Lens types:	Prismatic or Plain
Construction:	Bayonet with anti-tamper locking screw
Housing/Lens:	PC (UL94V0 f1)
IP rating:	IP65
Temp. range:	-25°C to +50°C
Tube life:	5 x 10 ⁶ (after which output is reduced to 70%)
RH:	90% at 20°C
Weight:	84g DC 89g AC



Part reference: B200STR

B200

Light source: Xenon Strobe
Flashing Beacon

Light output: 1J @ 0.75Hz

Voltage: 10-30V dc/ac: 135mA (@ 24V dc)
115V ac 50/60Hz: 30mA
230V ac 50/60Hz: 20mA

Part codes:	Voltage:
B200STR030B/x	10-30V dc/ac
B200STR115B/x	115V ac 50/60Hz
B200STR230B/x	230V ac 50/60Hz

x = Lens colour:
R=Red A=Amber B=Blue C=Clear G=Green Y=Yellow

Mounting accessories:

Right angle bracket for wall mounting: B200RAB001
Tube mounting assembly (137mm): B200TMA001

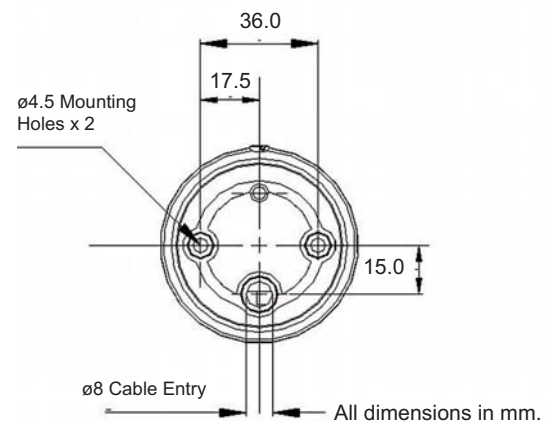
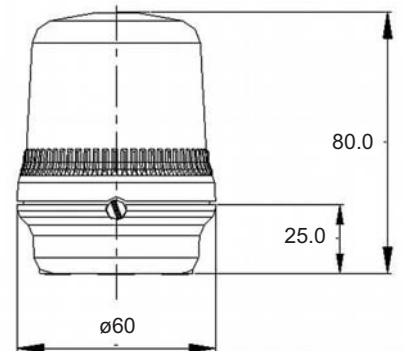

B200FLF Flashing Beacon Filament Lamp

SPECTRA range: The B200 series comprises a xenon strobe beacon, permanent filament lamp beacon, blinking filament lamp beacon and a permanent LED array beacon.

The surface mount base is supplied with neoprene mounting gasket and can also be supplied with a right angle bracket or with a tube mounting assembly.

Specifications:

Dimensions:	ø60 x 80mm
Terminals:	2.5 mm ²
Mounting:	Surface mount (bracket & pole mount accessories)
Lens colours:	Red, Amber, Blue, Clear, Green, Yellow
Lens types:	Prismatic or Plain
Construction:	Bayonet with anti-tamper locking screw
Housing/Lens:	PC (UL94V0 f1)
IP rating:	IP65
Temp. range:	-25°C to +50°C
RH:	90% at 20°C
Weight:	79g



Part reference: B200FLF

B200

Light source: Filament Lamp BA9s
Flashing Lamp Beacon

Light output: 5W @ 1Hz

Voltage:
12V dc: 500mA
24V dc: 250mA
48V dc: 120mA
115V ac: 35mA
230V ac: 25mA

Part codes:	Voltage:
B200FLF012B/x	12V dc
B200FLF024B/x	24V dc
B200FLF048B/x	48V dc
B200FLF115B/x	115V ac
B200FLF230B/x	230V ac

x = Lens colour:
R=Red A=Amber B=Blue C=Clear G=Green Y=Yellow

Mounting accessories:

Right angle bracket for wall mounting:
B200RAB001
Tube mounting assembly (137mm):
B200TMA001

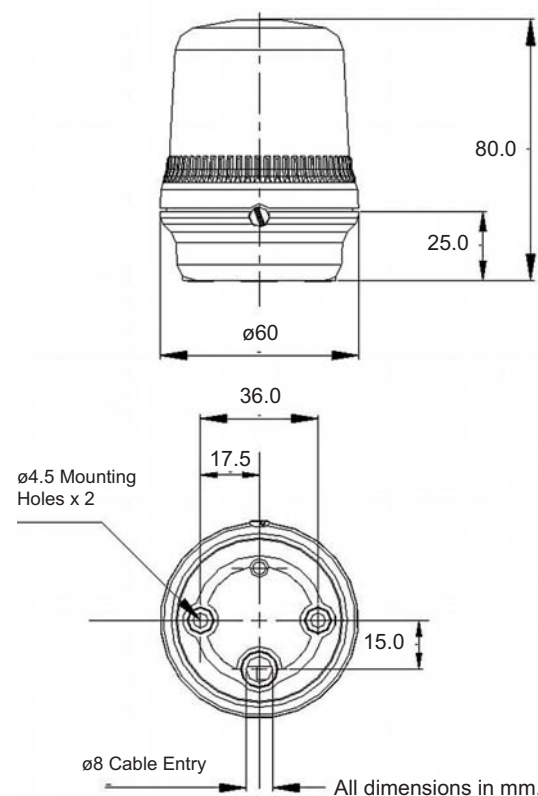

B200SLF Status Beacon Filament Lamp

SPECTRA range: The B200 series comprises a xenon strobe beacon, permanent filament lamp beacon, blinking filament lamp beacon and a permanent LED array beacon.

The surface mount base is supplied with neoprene mounting gasket and can also be supplied with a right angle bracket or with a tube mounting assembly.

Specifications:

Dimensions:	ø60 x 80mm
Terminals:	2.5 mm ²
Mounting:	Surface mount (bracket & pole mount accessories)
Lens colours:	Red, Amber, Blue, Clear, Green, Yellow
Lens types:	Prismatic or Plain
Construction:	Bayonet with anti-tamper locking screw
Housing/Lens:	PC (UL94V0 f1)
IP rating:	IP65
Temp. range:	-25°C to +50°C
RH:	90% at 20°C
Weight:	77g



Part reference: B200SLF

B200

Light source: Filament Lamp BA9s
Permanent Status Beacon

Light output: 5W

Voltage: 12 - 250V

Part codes: B200SLF250B/x
Voltage: 12-250V

x = Lens colour:
R=Red A=Amber B=Blue C=Clear G=Green Y=Yellow

Lamp/Bulb is not included.
Order code for the lamp/bulb is as follows:

Bulbs:

BR10125B	12V 5W
BR10245B	24V 5W
BR10485B	48V 5W
BR101305B	115V 5W
BR102305B	230V 5W

Mounting accessories:

Right angle bracket for wall mounting:
B200RAB001
Tube mounting assembly (137mm):
B200TMA001

