

B300STF Dual Frequency Xenon Beacon

SPECTRA range: The B300 series comprises Xenon strobe beacons, permanent filament bulb or halogen beacon, blinking filament bulb or halogen beacon, rotating beacon and a multi-function LED array beacon. The surface mount base can also be supplied with a right angle bracket or with a tube mounted assembly.

Specifications:

Dimensions:	ø100 x 150mm
Termination:	1.5 mm ² flying lead assembly
Cable entries:	1 x 5-7mm push through grommet 1 x M20 cable entry
Mounting:	Surface mount (bracket & pole mount accessories)
Lens colours:	Red, Amber, Blue, Clear, Green, Yellow
Lens types:	Prismatic or Plain
Construction:	Bayonet with anti-tamper locking screw
Housing/Lens:	PC (UL94V0 f1)
IP rating:	IP65
Temp. range:	-25°C to +50°C
Tube life:	5 x 10 ⁶ (after which output is reduced to 70%)
RH:	90% at 20°C
Weight:	325g



Part reference: B300STF

B300

Light source: Xenon Strobe Multi-frequency Flashing Beacon
The B300STF beacon offers 1.0Hz and 2.0Hz flash frequencies that can be selected remotely.

Light output: 5J @ 1.0Hz or 2.0Hz

Voltages:	12V dc/ac:	500mA/600mA
	24V dc/ac:	250mA/300mA
	48V dc/ac:	175mA/250mA

Order code:	Voltage:
B300STF012B/x	12V dc/ac
B300STF024B/x	24V dc/ac
B300STF048B/x	48V dc/ac

x = Lens colour:
R=Red A=Amber B=Blue C=Clear G=Green Y=Yellow

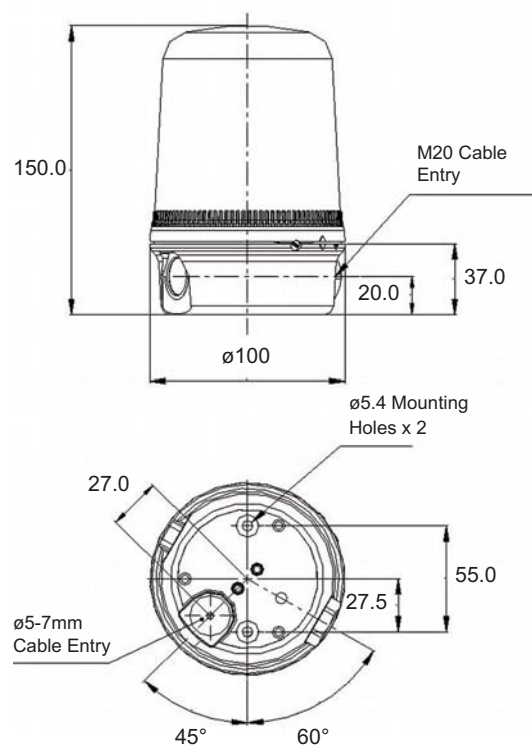
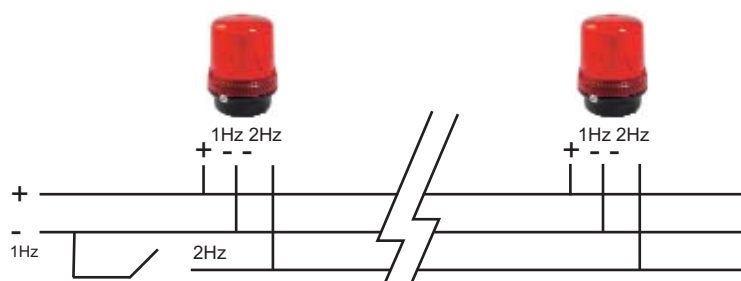

All dimensions in mm.

Mounting accessories:

Right angle bracket for wall mounting: B300RAB001
Tube mounting assembly (140mm): B300TMA001



B300SLF Status Beacon [Filament Lamp]



SPECTRA range: The B300 series comprises Xenon strobe beacons, permanent filament lamp or halogen beacon, blinking filament lamp or halogen beacon, rotating beacon and a multi-function LED array beacon. The surface mount base can also be supplied with a right angle bracket or with a tube mounted assembly.

Specifications:

- Dimensions: ø100 x 150mm
- Termination: 1.5 mm² flying lead assembly
- Cable entries: 1 x 5-7mm push through grommet
1 x M20 cable entry
- Mounting: Surface mount (bracket & pole mount accessories)
- Lens colours: Red, Amber, Blue, Clear, Green, Yellow
- Lens types: Prismatic or Plain
- Construction: Bayonet with anti-tamper locking screw
- Housing/Lens: PC (UL94V0 f1)
- IP rating: IP65
- Temp. range: -25°C to +50°C
- RH: 90% at 20°C
- Weight: 262g



Part reference: B300SLF

B300

Light source: Filament Lamp E14
Permanent Status Beacon

Light output: 25W

Voltage: 12 - 240V

Part codes: B300SLF250B/x
Voltage: 12-250V

x = Lens colour:
R=Red A=Amber B=Blue C=Clear G=Green Y=Yellow

Lamp/Bulb is not included.
Order code for the lamp/bulb is as follows:

Bulbs:

BB261225E	12V 25W
BB263025E	24V 25W
BB264825E	48V 25W
BB2613025E	115V 25W
BB2623525E	230V 25W

Mounting accessories:
Right angle bracket for wall mounting: B300RAB001
Tube mounting assembly (140mm): B300TMA001

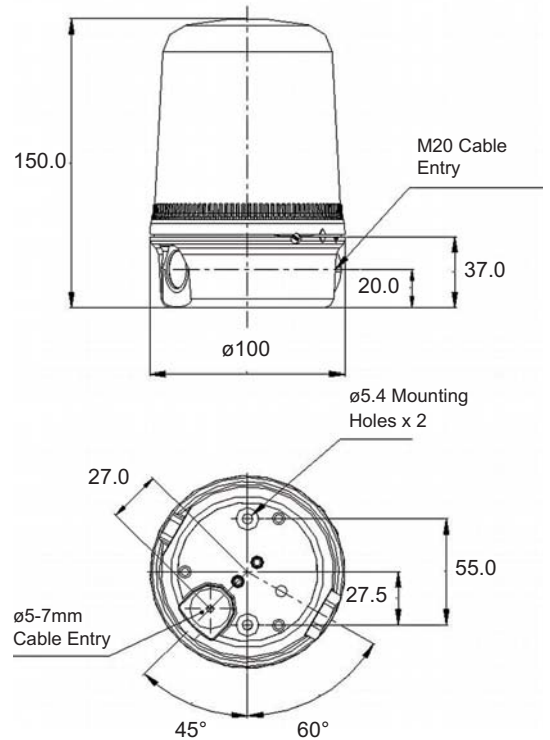

All dimensions in mm.



B300STR Xenon Beacon

SPECTRA range: The B300 series comprises Xenon strobe beacons, permanent filament bulb or halogen beacon, blinking filament bulb or halogen beacon, rotating beacon and a multi-function LED array beacon. The surface mount base can also be supplied with a right angle bracket or with a tube mounted assembly.

Specifications:

Dimensions:	ø100 x 150mm
Termination:	1.5 mm ² flying lead assembly
Cable entries:	1 x 5-7mm push through grommet 1 x M20 cable entry
Mounting:	Surface mount (bracket & pole mount accessories)
Lens colours:	Red, Amber, Blue, Clear, Green, Yellow
Lens types:	Prismatic or Plain
Construction:	Bayonet with anti-tamper locking screw
Housing/Lens:	PC (UL94V0 f1)
IP rating:	IP65
Temp. range:	-25°C to +50°C
Tube life:	5 x 10 ⁶ (after which output is reduced to 70%)
RH:	90% at 20°C
Weight:	325g DC 300g AC



Part reference: B300STR

B300

Light source: Xenon Strobe
Flashing Beacon

Light output: 5J (Ws) @ 1.0Hz

Voltages:

12V dc/ac:	500mA/600mA
24V dc/ac:	250mA/300mA
48V dc/ac:	175mA/250mA
115V ac 50/60Hz:	70mA
230V ac 50/60Hz:	35mA

Order code:	Voltage:
B300STR012B/x	12V dc/ac
B300STR024B/x	24V dc/ac
B300STR048B/x	48V dc/ac
B300STR115B/x	115V ac 50/60Hz
B300STR230B/x	230V ac 50/60Hz

x = Lens colour:
R=Red A=Amber B=Blue C=Clear G=Green Y=Yellow

Mounting accessories:

Right angle bracket for wall mounting: B300RAB001
Tube mounting assembly (140mm): B300TMA001

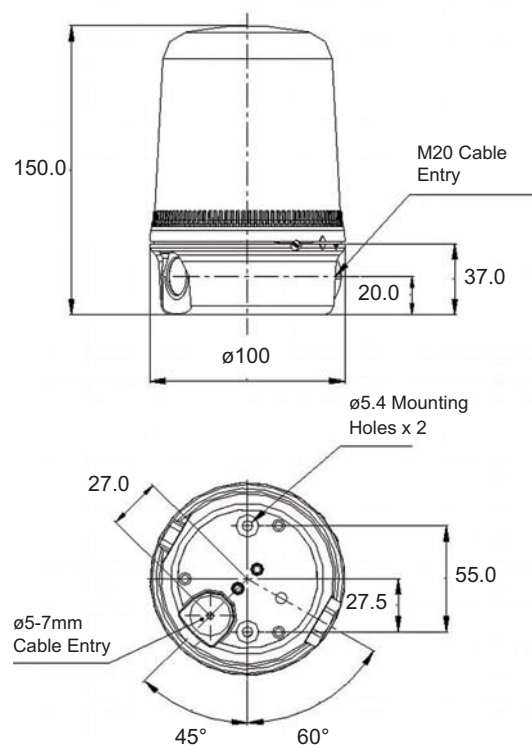

All dimensions in mm.



B300STS Synchronised Xenon Beacon

SPECTRA range: The B300 series comprises Xenon strobe beacons, permanent filament bulb or halogen beacon, blinking filament bulb or halogen beacon, rotating beacon and a multi-function LED array beacon. The surface mount base can also be supplied with a right angle bracket or with a tube mounted assembly.

Specifications:

Dimensions:	ø100 x 150mm
Termination:	1.5 mm ² flying lead assembly
Cable entries:	1 x 5-7mm push through grommet 1 x M20 cable entry
Mounting:	Surface mount (bracket & pole mount accessories)
Lens colours:	Red, Amber, Blue, Clear, Green, Yellow
Lens types:	Prismatic or Plain
Construction:	Bayonet with anti-tamper locking screw
Housing/Lens:	PC (UL94V0 f1)
IP rating:	IP65
Temp. range:	-25°C to +50°C
Tube life:	5 x 10 ⁶ (after which output is reduced to 70%)
RH:	90% at 20°C
Weight:	325g DC 300g AC



Part reference: B300STS

B300

Light source: Xenon Strobe
Synchronised Flashing Beacon
B300STS beacons will flash in synchronisation when powered from the same source

Light output: 5J (Ws) @ 1.0Hz

Voltages:	12V dc/ac:	500mA/600mA
	24V dc/ac:	250mA/300mA
	48V dc/ac:	175mA/250mA
	115V ac 50/60Hz:	70mA
	230V ac 50/60Hz:	35mA

Order code:	Voltage:
B300STS012B/x	12V dc/ac
B300STS024B/x	24V dc/ac
B300STS048B/x	48V dc/ac
B300STS115B/x	115V ac 50/60Hz
B300STS230B/x	230V ac 50/60Hz

x = Lens colour:
R=Red A=Amber B=Blue C=Clear G=Green Y=Yellow

Mounting accessories:

Right angle bracket for wall mounting: B300RAB001
Tube mounting assembly (140mm): B300TMA001

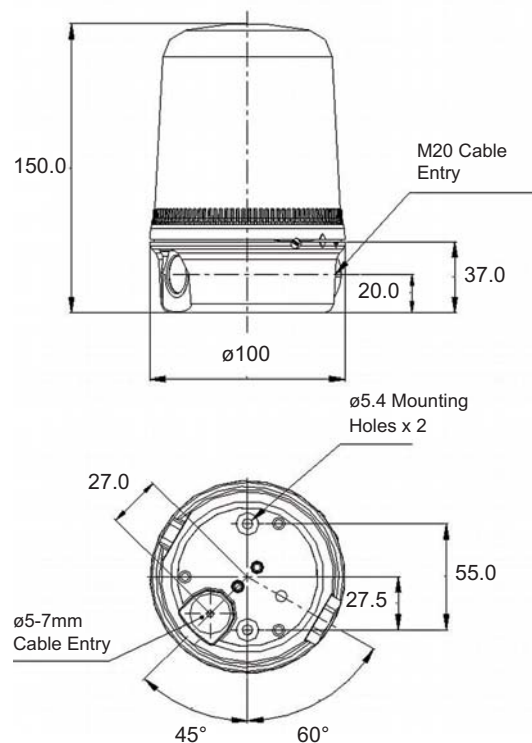

All dimensions in mm.



B300RTH Rotating Beacon [Halogen Bulb]

SPECTRA range: The B300 series comprises Xenon strobe beacons, permanent filament bulb or halogen beacon, blinking filament bulb or halogen beacon, rotating beacon and a multi-function LED array beacon. The surface mount base can also be supplied with a right angle bracket or with a tube mounted assembly.

Specifications:

Dimensions:	ø100 x 150mm
Termination:	1.5 mm ² flying lead assembly
Cable entries:	1 x 5-7mm push through grommet 1 x M20 cable entry
Mounting:	Surface mount (bracket & pole mount accessories)
Lens colours:	Red, Amber, Blue, Clear, Green, Yellow
Lens types:	Prismatic or Plain
Construction:	Bayonet with anti-tamper locking screw
Housing/Lens:	PC (UL94V0 f1)
IP rating:	IP65
Temp. range:	-25°C to +50°C
RH:	90% at 20°C
Weight:	370g



Part reference: B300RTH

B300

Light source: Halogen Bulb G6,35 / GY6,35
Rotating Beacon

Rotation: 180PM (+/-30RPM)

Drive life: >5,000 hrs

Duty cycle: 100%

Light output: 20W/25W

Voltage:

12V dc:	1.72A
24V dc:	0.91A
115V ac 50/60Hz:	216mA
230V ac 50/60Hz:	117mA

Part codes:	Voltage:
B300RTH012B/x	12V dc
B300RTH024B/x	24V dc
B300RTH115B/x	115V ac 50/60Hz
B300RTH230B/x	230V ac 50/60Hz

x = Lens colour:
R=Red A=Amber B=Blue C=Clear G=Green
Y=Yellow

Mounting accessories:

Right angle bracket for wall mounting: B300RAB001
Tube mounting assembly (140mm): B300TMA001

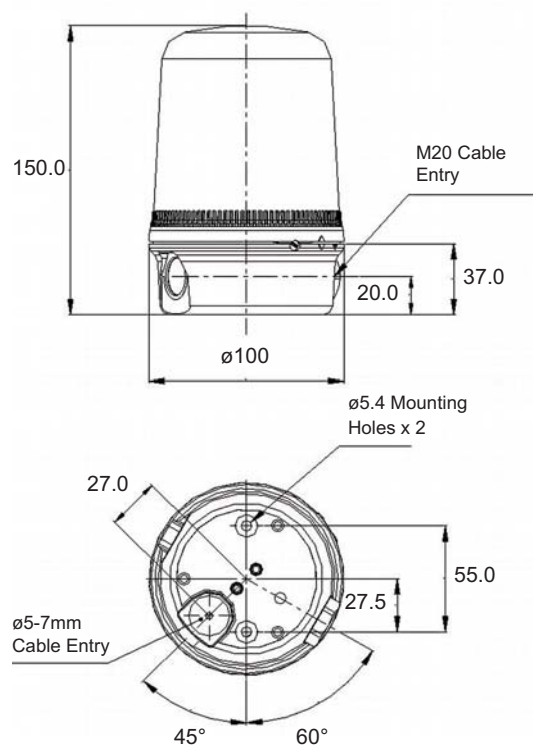

All dimensions in mm.



B300FLF Blinking Beacon [Filament Lamp]

SPECTRA range: The B300 series comprises Xenon strobe beacons, permanent filament lamp or halogen beacon, blinking filament lamp or halogen beacon, rotating beacon and a multi-function LED array beacon. The surface mount base can also be supplied with a right angle bracket or with a tube mounted assembly.

Specifications:

Dimensions:	ø100 x 150mm
Termination:	1.5 mm ² flying lead assembly
Cable entries:	1 x 5-7mm push through grommet 1 x M20 cable entry
Mounting:	Surface mount (bracket & pole mount accessories)
Lens colours:	Red, Amber, Blue, Clear, Green, Yellow
Lens types:	Prismatic or Plain
Construction:	Bayonet with anti-tamper locking screw
Housing/Lens:	PC (UL94V0 f1)
IP rating:	IP65
Temp. range:	-25°C to +50°C
RH:	90% at 20°C
Weight:	283g



Part reference: B300FLF

B300

Light source: Filament Lamp E14
Blinking Beacon
The B300FLF has three blinking frequencies selectable during installation

Light output: 25W @ 0.5Hz / 1Hz / 2Hz
(On board selection)

Voltage:

12V dc:	1.75A
24V dc:	1.1A
48V dc:	0.8A
115V ac:	255mA
230V ac:	130mA

Part codes:	Voltage:
B300FLF012B/x	12V dc
B300FLF024B/x	24V dc
B300FLF048B/x	48V dc
B300FLF115B/x	115V ac
B300FLF230B/x	230V ac

x = Lens colour:
R=Red A=Amber B=Blue C=Clear G=Green Y=Yellow

Mounting accessories:

Right angle bracket for wall mounting: B300RAB001
Tube mounting assembly (140mm): B300TMA001

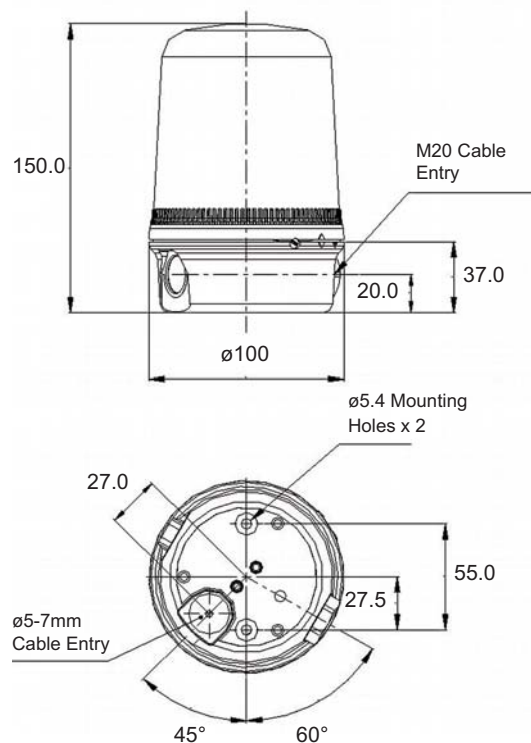

All dimensions in mm.



B300FLH Blinking Beacon [Halogen Lamp]

SPECTRA range: The B300 series comprises Xenon strobe beacons, permanent filament lamp or halogen beacon, blinking filament lamp or halogen beacon, rotating beacon and a multi-function LED array beacon. The surface mount base can also be supplied with a right angle bracket or with a tube mounted assembly.

Specifications:

Dimensions:	ø100 x 150mm
Termination:	1.5 mm ² flying lead assembly
Cable entries:	1 x 5-7mm push through grommet 1 x M20 cable entry
Mounting:	Surface mount (bracket & pole mount accessories)
Lens colours:	Red, Amber, Blue, Clear, Green, Yellow
Lens types:	Prismatic or Plain
Construction:	Bayonet with anti-tamper locking screw
Housing/Lens:	PC (UL94V0 f1)
IP rating:	IP65
Temp. range:	-25°C to +50°C
RH:	90% at 20°C
Weight:	279g



Part reference: B300FLH

B300

Light source: Halogen Lamp G6,35 / GY6,35
Blinking Beacon
The B300FLH has three blinking frequencies selectable during installation.

Light output: 20W/25W @ 0.5Hz / 1Hz / 2Hz

Voltage:
12V dc: 1.7A
24V dc: 1.0A
115V ac: 208mA
230V ac: 116mA

Part codes:	Voltage:
B300FLH012B/x	12V dc
B300FLH024B/x	24V dc
B300FLH115B/x	115V ac
B300FLH230B/x	230V ac

x = Lens colour:
R=Red A=Amber B=Blue C=Clear G=Green Y=Yellow

Mounting accessories:

Right angle bracket for wall mounting: B300RAB001
Tube mounting assembly (140mm): B300TMA001

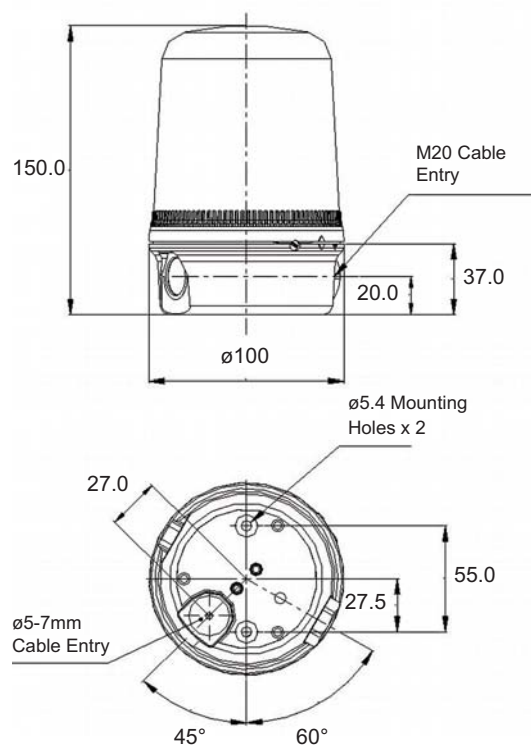

All dimensions in mm.



B300SLH Status Beacon [Halogen Lamp]

SPECTRA range: The B300 series comprises Xenon strobe beacons, permanent filament lamp or halogen beacon, blinking filament lamp or halogen beacon and a multi-function LED array beacon. The surface mount base can also be supplied with a right angle bracket or with a tube mounted assembly.

Specifications:

Dimensions:	ø100 x 150mm
Termination:	1.5 mm ² flying lead assembly
Cable entries:	1 x 5-7mm push through grommet 1 x M20 cable entry
Mounting:	Surface mount (bracket & pole mount accessories)
Lens colours:	Red, Amber, Blue, Clear, Green, Yellow
Lens types:	Prismatic or Plain
Construction:	Bayonet with anti-tamper locking screw
Housing/Lens:	PC (UL94V0 f1)
IP rating:	IP65
Temp. range:	-25°C to +50°C
RH:	90% at 20°C
Weight:	262g



Part reference: B300SLH

B300

Light source: Halogen Lamp G6,35 / GY6,35
Permanent Status Beacon

Light output: 20W/25W

Voltage: 12 - 250V

Part codes: B300SLH250B/x
Voltage: 12-250V

x = Lens colour:
R=Red A=Amber B=Blue C=Clear G=Green Y=Yellow

Lamp/Bulb is not included.
Order codes for the lamp/bulb is as follows:

Bulbs:

BJC20W12VCL	12V 20W
BJC20W24VCL	24V 20W
BJCD25W120VCL	115V 25W
BJCD25W230VCL	230V 25W

Mounting accessories:

Right angle bracket for wall mounting: B300RAB001
Tube mounting assembly (140mm): B300TMA001

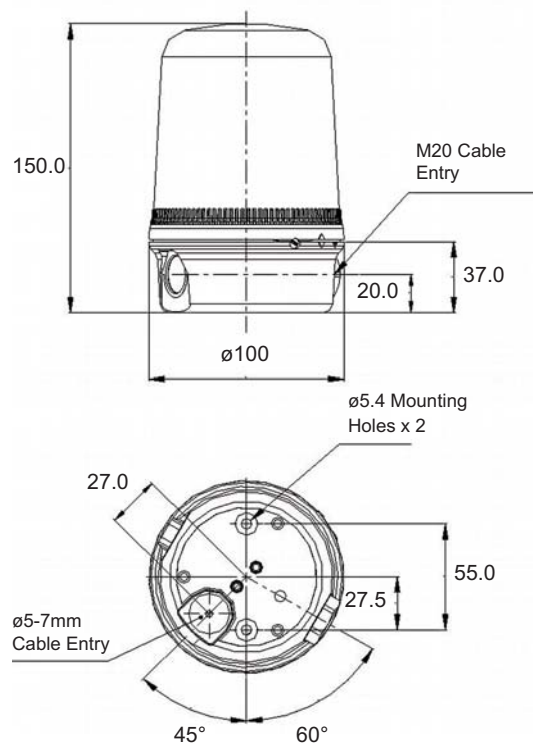

All dimensions in mm.

